

# Davis-Lynch CentraLaser™ with WearSox™ Spray-Metal Stop Ribs

**Davis**  
**DAVIS-LYNCH, INC.**

**WEARSOX™**

Davis CentraLaser™ patent pending.  
WearSox™ patented by WearSox LP.

# Features & Benefits

- Davis CentraLasers™ with WearSox™ Spray-Metal Stop Ribs can be installed directly on casing joints, eliminating the high costs associated with Centralizer Subs.
- WearSox™ Spray-Metal Stop Ribs allow the centralizer to be pulled into or out of the hole for decreased drag and starting forces.
- WearSox™ Spray-Metal Stop Ribs are full length, to prevent possible rotation of the centralizer bows underneath the ribs which could prevent collapse of the bows.
- A thin coating of WearSox™ Spray-Metal on the bow OD reduces starting and drag forces of the CentraLaser™ passing through restrictions, as well as decreasing wear of the bow itself.



# Features & Benefits

(continued)

- Davis CentraLaser™ with WearSox™ Spray-Metal Stop Ribs is **the strongest combination Bow-Spring Centralizer and stop device available on the market that can be directly applied to the casing.**
- Bands of WearSox™ Spray-Metal immediately above and below the CentraLaser™, which are the same OD as the end collar, act as a centralizing guide eliminating drag of end collar edges against the open hole.
- Davis CentraLasers™ provide optimum combination of strength, reduced starting and drag forces, as well as high restoring forces specifically designed for close-tolerance bi-center hole applications.
- WearSox™ Spray-Metal Stop Ribs application will not apply heat to the casing over 300°F, therefore casing metallurgy will not change.



# WearSox™ Spray-Metal Stop Ribs Performance Testing

- Davis CentraLaser™ with WearSox™ Spray-Metal Stop Ribs were tested to verify the holding performance of the Stop Ribs together with the strength of the CentraLaser™.
- Force was applied to the CentraLaser™ end collar against the WearSox™ Spray-Metal Stop Ribs using a load frame until the end collar or stop ribs failed.
- The failure mode for 9-7/8" size was a combination of rib-shearing and end collar splitting. The failure mode for the 11-7/8" size was the rib-shearing.

Sample	Casing Outer Diameter (inches)	Initial Load at Movement (KIPS)	Final Load at Failure (KIPS)
WearSox	9-7/8	42.17	107.58
WearSox	11-7/8	57.48	97.67



Casing Size	Bow OD +/- 1/4"	End Collar & Bow Thickness +/- .01"	End Collar OD +/- .07"	Min. Pass-Thru ID	Stop Collar Type	WearSox Holding Force (kips)	Starting Force (lbs)	Drag Force (lbs)	Restoring Force (lbs)	Open Hole Size	Open Hole Restoring Force (lbs)
7"	9.000	0.160	7.460	7.875	WearSox	70	3287	1832	2344	8-1/2"	1395
7-5/8"	9.500	0.160	8.200	8.500	WearSox	75	1335	1282	1359	9-7/8"	760
7-3/4"	9.750	0.160	8.330	8.500	WearSox	80	1681	1189	1535	9-7/8"	1043
9-5/8"	12.250	0.160	10.100	10.625	WearSox	100	2535	841	1729	12-1/4"	882
9-7/8"	12.500	0.160	10.350	10.625	WearSox	100	2442	868	3305	12-1/4"	1060
11-3/4"	14.500	0.100	12.100	12.250	WearSox	90	2500	1700	2140	13-1/2"	871
11-7/8"	14.500	0.100	12.150	12.250	WearSox	90	2477	593	2252	13-1/2"	938
14"	18.000	0.125	14.430	14.670	WearSox	100	3318	1854	3122	16"	914

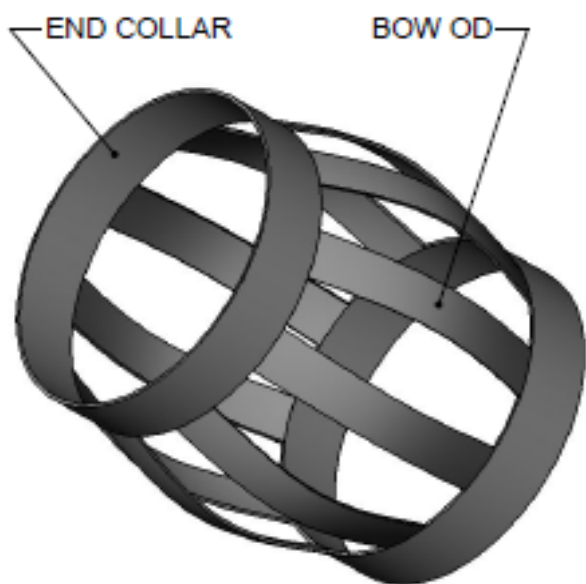

STANDARD CENTRALASER® CENTRALIZER

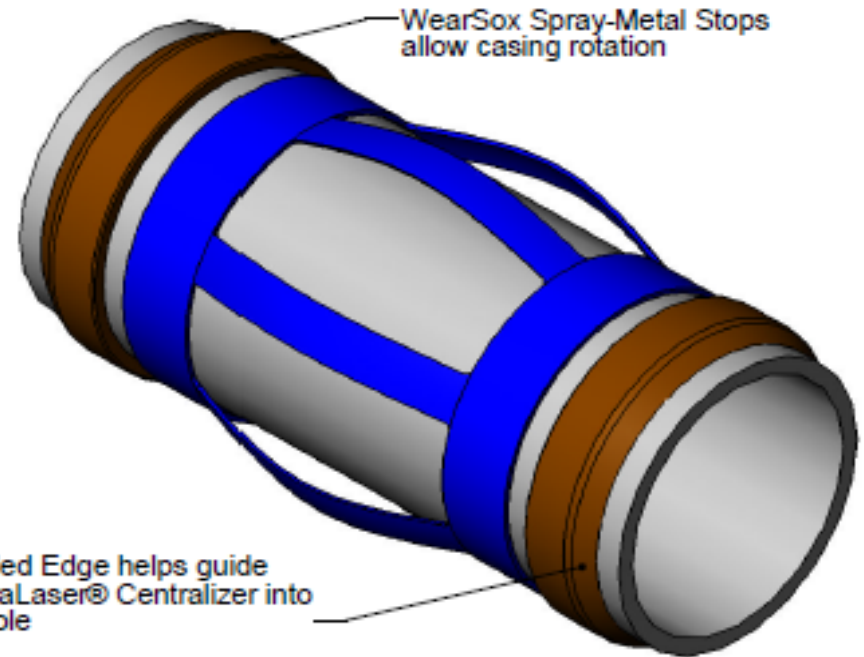

Centralaser® Centralizers installed on casing with WearSox Spray-Metal Stops

REVISED 7/1/11

**CONFIDENTIAL**  
THIS DRAWING IS THE  
SOLE PROPERTY OF:  
**DAVIS**  
DAVIS-LYNCH, LLC

STD. TOLERANCES U.O.S.:  
XXX = ± .010" Ø ± 1/32" LENGTH  
XXX = ± .004" Ø ± 1/64" LENGTH  
FRACTIONS = ± 1/32"  
BREAK EDGES 1/32" x 45°  
ALL ANGLES 45°  
STD. SURFACE FINISH = 125rms

MATERIAL: **AISI 4130 HT**  
REV. # REV. DATE DESCRIPTION OF REVISION

SCALE: **1:5**  
APPROVED

TOOL NAME: **CENTRALASER WEARSOX CHART**  
OWNER: **RAC** DWG DATE: **3/13/2009** PART NAME: **Standard Centralaser® Centralizers & w/ WearSox Stops**  
APPROVED BY: **JCE** REVISION DATE: **7/8/2011** DRAWING NO: **Centralaser-WearSox-Chart**